



DESCRIPTION:

Strainers for steam, air, oil or water piping, protect equipment, steam traps, valves etc. from dirt, rust or scale, and debris, in the pipeline.

FEATURES:

Simple yet sound construction ensures long service life. A stainless steel strainer screen with a large surface area ensures minimum pressure drop and requires less frequent cleaning. Designed for easy in-line cleaning and maintenance.

LIMITING CONDITIONS:

Maximum Pressure rating	570 psig
Maximum Temperature rating	645 °F

SIZES: 1/2", 3/4", 1"

CONNECTIONS: Screwed (NPT) / Socket Weld

MATERIAL:

No.	PART	MATERIAL	QTY. (Nos.)
1.	Body	CS / SS	01
2.	Strainer Cap	CS / SS	01
3.	Strainer Screen	AISI 304 (40 mesh)	01
4.	Gasket	NON ASBESTOS	01

DIMENSIONS (approx. in inches)

MODEL	SIZE	A	B	Weight (lbs)
PS11	1/2"	2.95	2.75	2.0
PS11	3/4"	2.95	2.75	2.0
PS12	1"	3.75	3.45	3.5

AVAILABLE SPARES:

Strainer Screen (Packet of 5)

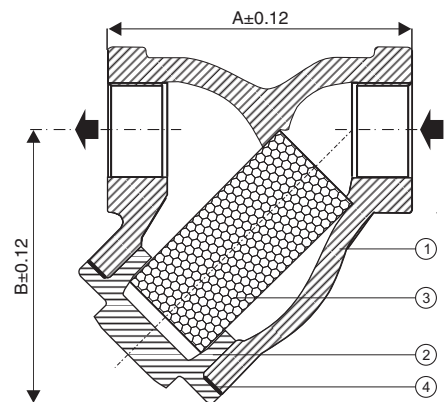

INSTALLATION:

For horizontal installations, the strainer should be installed with the screen in the horizontal plane or below the centre-line of the pipe. Ensure accessibility of the strainer cap for cleaning.

MAINTENANCE:

This product can be maintained without disturbing the piping connections. Complete isolation of the strainer from both supply and return lines is required before any servicing is carried out.

The strainer should be disassembled periodically for cleaning the screen.

IMPORTANT:

For new pipelines, ensure that the lines are properly flushed, prior to fitting the strainer.

Local regulations may restrict the use of this product below the conditions quoted. Limiting conditions refer to standard connections only. In the interest of development and improvement of the product, we reserve the right to change the specifications without prior notice.

