



DESCRIPTION:

Thermodynamic steam trap without integral strainer. Compact, light weight design, in full stainless steel construction.

FEATURES:

Better corrosion and wear resistance ensured by the total stainless steel construction.

It meets the requirements of quick response applications in the steam system.

The disc and seat are hardened to withstand continuous and prolonged operation. Condensate entry below the disc, concentric to the disc / seat ensures a clean and parallel lift of the disc with reference to the seat, eliminating localized wear and tear.

Ideal for fluctuating loads and pressures.

Perfect shut-off, no steam loss.

SIZES : 1/4", 3/8", 1/2", 3/4", 1"

CONNECTIONS : Screwed (NPT)

LIMITING CONDITIONS:

PMA: Maximum allowable pressure	600 psig
TMA: Maximum allowable temperature	800 °F
Maximum operating back pressure at the outlet should not exceed 80% of the inlet pressure.	
Minimum differential pressure for satisfactory operation	3.5 psi

INSTALLATION:

The trap will operate in any position, but the preferred installation is in the horizontal plane with the cap on the top. Full port isolating valves should be installed upstream and downstream of the trap for safe maintenance. Always open isolation valves slowly until normal operating conditions are achieved to avoid system shocks.

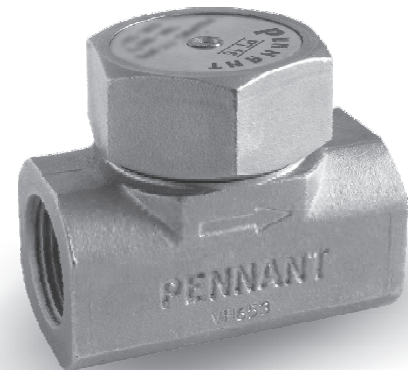

MAINTENANCE:

The trap can be maintained without disturbing the piping connections. Ensure that the trap is isolated - upstream and downstream - before attempting to dismantle it. **ALLOW THE TRAP TO COOL BEFORE DISMANTLING**

Periodic cleaning of the disc and seat will facilitate trouble-free performance. Do not use abrasive / corrosive media for cleaning.

Only the disc and seat are subject to wear. A worn disc can be replaced and slight seat wear can be corrected by resurfacing on a lap plate.

IMPORTANT:

For new installations, the system should be properly flushed prior to fitting the trap.

MATERIAL :

No.	PART	MATERIAL	QTY. (Nos.)
1.	BODY (Seat Hardened)	ASTM A743 Gr. CA 40	01
2.	DISC CAP	ASTM A743 Gr. CA 40	01
3.	DISC (Hardened)	AISI 410	01

DIMENSIONS: (approx.) in inches

SIZE	A	B	C	D	E	F	Weight (lbs)
1/4"	1.69	2.44	2.36	1.57	1.5	1.91	1.43
3/8"	1.69	2.44	2.36	1.57	1.5	1.91	1.43
1/2"	1.69	2.44	2.56	1.57	1.5	1.91	1.65
3/4"	1.69	2.44	2.56	1.57	1.5	1.91	1.65
1"	1.97	2.87	3.35	1.77	1.81	2.27	3.52

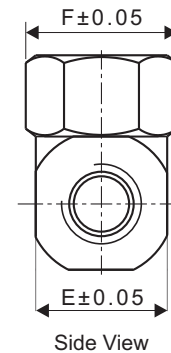
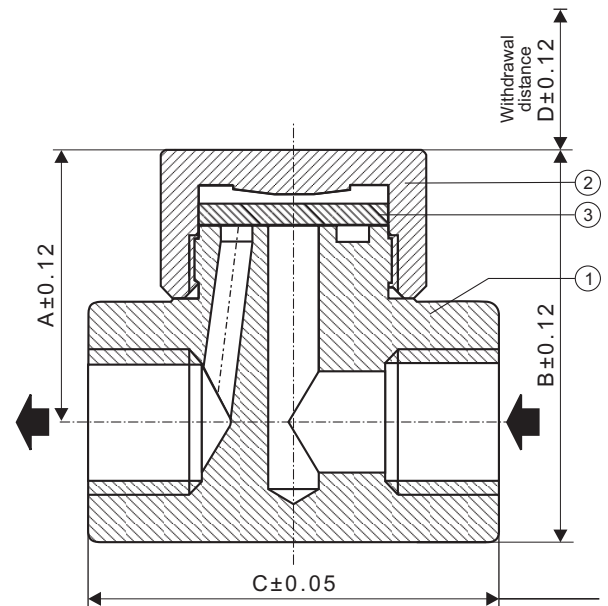

AVAILABLE SPARES:

Disc (Packet of 5)

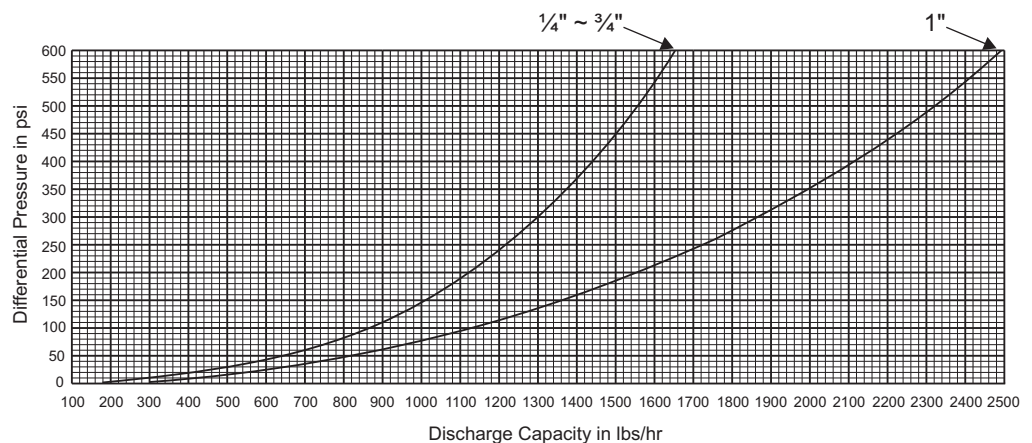

Local regulations may restrict the use of this product below the conditions quoted. Limiting conditions refer to standard connections only. In the interest of development and improvement of the product, we reserve the right to change the specifications without prior notice.