



**DESCRIPTION:**

PT62 float and thermostatic (internal air vent) steam traps are designed for draining condensate from all types of low and medium pressure steam heating and process equipment.

Typical applications include unit heaters, heat exchangers, driers and jacketed vessels.

Horizontal installation.

Available types:

PT 62 - with thermostatic air vent

PT 62S- SLR (with steam lock release)

PT 62C - with thermostatic air vent and SLR.

**FEATURES:**

Modulating discharge.

Discharges condensate at steam temperature.

Excellent air venting (by thermostatic air vent).

**USE:** Saturated and superheated steam.

**SIZES:** 1/2", 3/4", 1"

**CONNECTIONS:** Screwed (NPT)

Flanged/ SW for CS traps.

**LIMITING CONDITIONS:**

PMA: Max allowable pressure	228 psig
TMA: Max. allowable temperature	428 °F
PMO: Max operating pressure	200 psig
TMO: Max. operating temperature	428 °F
Body shell design rating	285 psig, 800 °F



**INSTALLATION:**

Horizontal installation with flow from left to right

The trap should be installed horizontally below the drain point of the equipment in a position such that the float arm is in a horizontal plane and the float rises and falls vertically, with the flow direction as indicated on the cover.

The word 'TOP' on the nameplate indicates the top side of the trap.

Max. differential pressure range:

PT62-65 : 65 psi

PT62-145: 145 psi

PT62-200: 200 psi

**TRAP DISCHARGE CAPACITY IN lbs/hr**

		DIFFERENTIAL PRESSURE (psi)																
MODEL	SIZE	7	15	21.5	28.5	42.5	57	65	70	85	100	115	128	145	157	170	185	200
PT62-65	1/2", 3/4"	440	616	705	770	880	1000	1090	-----	-----	-----	-----	-----	-----	-----	-----	-----	-----
PT62-65	1"	1850	2080	2310	2540	2990	3455	3685	-----	-----	-----	-----	-----	-----	-----	-----	-----	-----
PT62-145	1/2", 3/4"	297	330	365	396	462	530	560	615	660	770	860	890	925	-----	-----	-----	-----
PT62-145	1"	1330	1440	1562	1672	1915	2145	2255	2376	2610	2840	3070	3300	3530	-----	-----	-----	-----
PT62-200	1/2", 3/4"	275	308	330	363	418	485	506	540	595	650	715	770	825	890	946	1000	1060
PT62-200	1"	935	1000	1056	1122	1243	1365	1420	1485	1606	1727	1848	1970	2090	2210	2343	2465	2585

Recommended safety factor: steady condns. 1.5 - 2; fluctuating condns. 2-3

**MATERIAL:**

NO.	PART	MATERIAL	QTY.(Nos.)
1.	BODY	ASTM A216 Gr. WCB / CI *	01
2.	COVER	ASTM A216 Gr. WCB / CI *	01
3.	GASKET	NON ASBESTOS	01
4.	VALVE SEAT	Cr. STEEL	01
5.	BALL FLOAT & LEVER ASSY.	SS	01
6.	AIR VENT	BIMETAL / SS	01
7.	BOLT	ASTM 193 Gr. B7	04
8.	DRAIN PLUG	CS	01
9.	BRACKET ASSY.	AISI 304	01
10.	GASKET	COPPER	01
11.	SLR UNIT	AISI 304	01

\*CI only for 1" size traps.

OPTIONAL: SS Diaphragm Air Vent

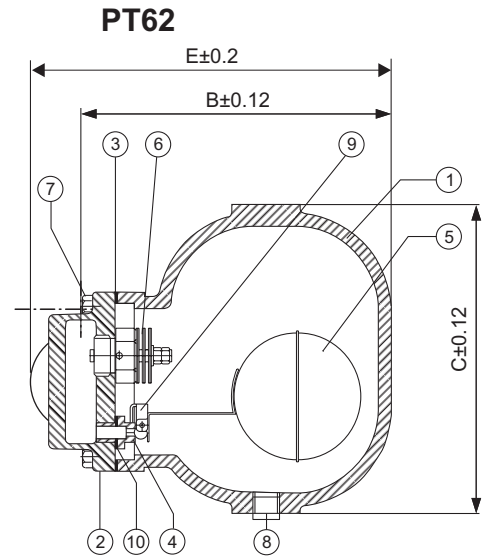
**DIMENSIONS (approx.) in inches**

SIZE	A	B	C	D	E	F	G	
							#150	#300
1/2"	3.95	5.50	4.10	2.05	6.40	7.20	7.10	7.44
3/4"	3.95	5.50	4.10	2.05	6.40	7.20	7.20	7.60
1"	4.75	7.65	7.65	4.35	8.65	9.85	8.25	8.66

**WEIGHTS (approx.) in lbs**

SIZE	NPT / SW ENDS	FLANGED ENDS	
		#150	#300
1/2"	9.9	12.0	13.0
3/4"	9.9	12.8	14.3
1"	19.8	28.5	31.0

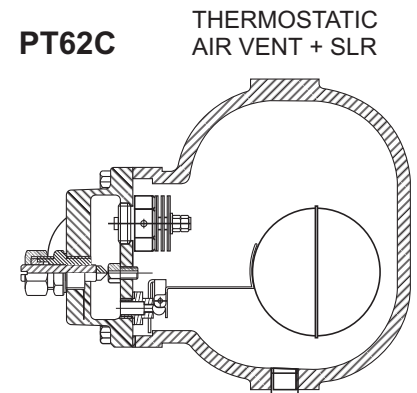
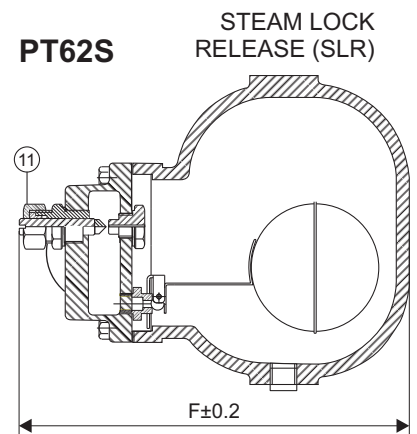
**AVAILABLE SPARES:**

Valve Seat, Ball Float & Lever Assy.,  
 Airvent, Gaskets.

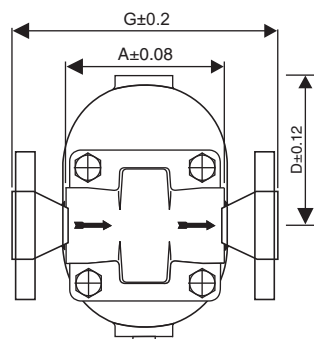

Local regulations may restrict the use of this product below the conditions quoted. Limiting conditions refer to standard connections only. In the interest of development and improvement of the product, we reserve the right to change the specifications without prior notice.