



**DESCRIPTION:**

PT64 float and thermostatic (integral air vent) steam traps are designed for draining condensate from building heating installations. They can also be used in low pressure industrial installations.

**FEATURES:**

Modulating discharge of hot condensate at close to saturation temperature.

Good air venting facilitates a fast start-up.

**USE:** Saturated and superheated steam

**SIZES:** 1¼", 1½", 2"

**CONNECTIONS:** Screwed (NPT)

**LIMITING CONDITIONS:**

PMA: Max allowable pressure	225 psig
TMA: Max. allowable temperature	425 °F
PMO: Max operating pressure	125 psig
TMO: Max. operating temperature	425 °F



**INSTALLATION:**

It is important to install the trap with the label on the top and the connecting pipes horizontal.

Inlet and outlet connections are marked on the housing.

For effective condensate removal, the trap should be fitted below the drain point of the system being drained.

**TRAP DISCHARGE CAPACITY IN lbs/hr**

MODEL	Size (in)	Orifice Size (in)	Differential Pressure (psig)													
			¼	½	1	2	5	10	15	20	30	40	50	75	100	125
Discharge Capacities in lbs																
PT64-15	1.¼, 1.½	0.5	1050	1675	2400	3325	5000	6625	7550							
PT64-15	2	0.625	2275	2775	3625	4625	6900	9050	10875							
PT64-30	1.¼, 1.½	0.39	1000	1325	1700	2250	3385	4620	5530	6000	7000					
PT64-30	2	0.5	1300	1780	2550	3400	5180	6815	7800	8550	9990					
PT64-75	1.¼, 1.½	0.312	535	720	970	1300	1910	2660	3050	3400	4000	4390	4750	5420		
PT64-75	2	0.421	830	1090	1480	2000	3080	4125	4725	5200	5800	6425	6850	7735		
PT64-125	1.¼, 1.½	0.246	380	510	675	880	1310	1700	2065	2315	2710	3035	3225	3790	4200	4480
PT64-125	2	0.332	550	670	875	1240	1975	2630	3050	3300	3830	4220	4600	5500	6120	6630

### MATERIAL:

No.	PART	MATERIAL	QTY. (Nos.)
1.	BODY	CAST IRON	01
2.	COVER	CAST IRON	01
3.	BALL FLOAT & LEVER ASSY.	STAINLESS STEEL	01
4.	BRACKET	AISI 304	01
5.	VALVE SEAT	Cr. STEEL	01
6.	AIR VENT	STAINLESS STEEL	01
7.	GASKET	NON CAF	01
8.	DRAIN PLUG	CS	01
9.	BOLT	HIGH TENSILE	06 / 08
10.	GASKET	NON CAF	01

**WEIGHT:** 1¼", 1½" - 15.4 lbs (approx.)  
 2" - 26.5 lbs (approx.)

### HOW TO ORDER:

Refer to 'How to Order' of product catalog.

### AVAILABLE SPARES:

Valve Seat, Ball Float & Lever Assy.,  
 Air Vent, Gaskets.

### PT64 1¼", 1½"

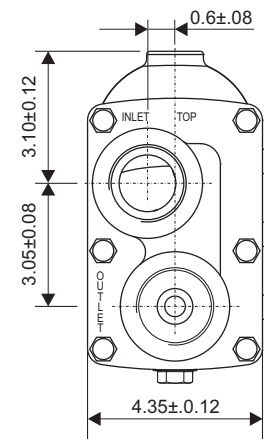
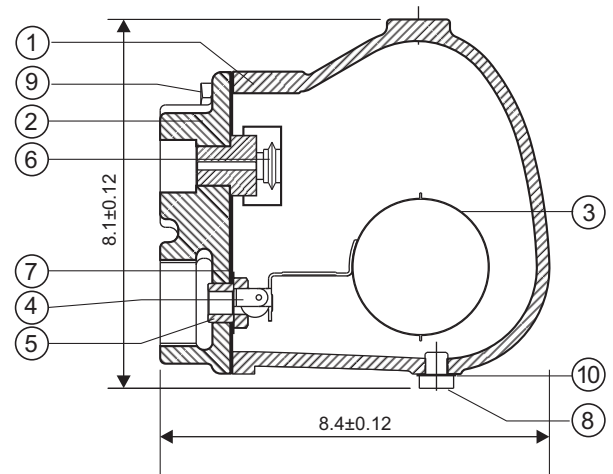

### PT64 2"

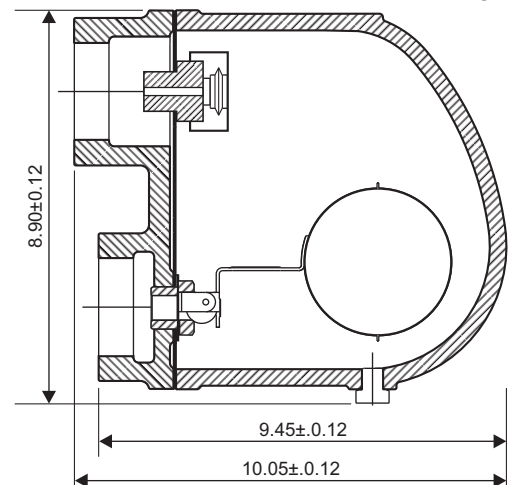
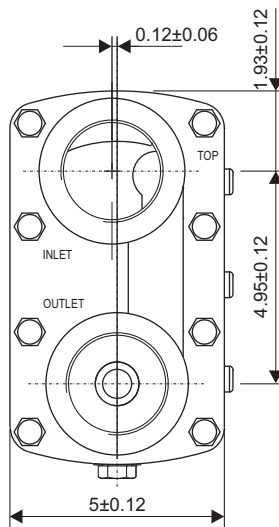

Local regulations may restrict the use of this product below the conditions quoted. Limiting conditions refer to standard connections only. In the interest of development and improvement of the product, we reserve the right to change the specifications without prior notice.